



This is the publisher's version of a work that was accepted for publication in the following source:

Slater, K. D., N. C. Sinclair, T. S. Nelson, P. J. Blamey & H. J. McDermott (2015). neuroBi: A Highly Configurable Neurostimulator for a Retinal Prosthesis and Other Applications. *IEEE Journal of Translational Engineering in Health and Medicine* **3**: e3800111.

This is an open access article.

Received 8 August 2014; revised 26 March 2015; accepted 2 July 2015. Date of publication 13 July 2015; date of current version 6 August 2015.

Digital Object Identifier 10.1109/JTEHM.2015.2455507

neuroBi: A Highly Configurable Neurostimulator for a Retinal Prosthesis and Other Applications

KYLE D. SLATER^{*1}, NICHOLAS C. SINCLAIR^{*1}, TIMOTHY S. NELSON¹, PETER J. BLAMEY^{1,2}, AND HUGH J. McDERMOTT^{1,2}, (Fellow, IEEE), for the Bionic Vision Australia Consortium[†]

¹Bionics Institute, East Melbourne, VIC 3002, Australia

²Department of Medical Bionics, The University of Melbourne, Melbourne, VIC 3010, Australia

*indicates co-first author.

CORRESPONDING AUTHOR: N. C. SINCLAIR (nsinclair@bionicsinstitute.org)

This work was supported in part by the Colonial Foundation, in part by the Bertalli Family Foundation, in part by the National Health and Medical Research Council under Grant 100764, and in part by the Australian Research Council through its Special Research Initiative in Bionic Vision Science and Technology grant to Bionic Vision Australia. The Bionics Institute acknowledge the support they receive from the Victorian Government through its operational infrastructure program.

ABSTRACT To evaluate the efficacy of a suprachoroidal retinal prosthesis, a highly configurable external neurostimulator is required. In order to meet functional and safety specifications, it was necessary to develop a custom device. A system is presented which can deliver charge-balanced, constant-current biphasic pulses, with widely adjustable parameters, to arbitrary configurations of output electrodes. This system is shown to be effective in eliciting visual percepts in a patient with approximately 20 years of light perception vision only due to retinitis pigmentosa, using an electrode array implanted in the suprachoroidal space of the eye. The flexibility of the system also makes it suitable for use in a number of other emerging clinical neurostimulation applications, including epileptic seizure suppression and closed-loop deep brain stimulation. Clinical trial registration number NCT01603576 (www.clinicaltrials.gov).

INDEX TERMS Neurostimulator, electrical stimulation, neural prosthesis, visual prosthesis, cortical stimulation, deep brain stimulation, bionic eye, suprachoroidal.

I. INTRODUCTION

Neural stimulation has a long history of use in a range of therapeutic applications, including regulating organ function and treating a variety of neurological disorders [1]–[3]. Neurostimulators are also used to provide forms of sensory perception; for example, electrical stimulation of auditory neurons using electrodes implanted in the cochlea can provide hearing sensations to people with a severe to profound hearing impairment [4]. A related application is visual prostheses (“bionic eyes”), in which electrodes implanted within the

visual system are used to electrically elicit visual percepts in people with minimal light perception. This research has expanded in recent years, and several distinct techniques are being developed [5]. These include stimulation of the visual cortex using cortical electrode arrays [6], [7] and stimulation of retinal neurons using electrode arrays implanted at various intraocular sites [8]–[10].

One such device being developed by Bionic Vision Australia (BVA) targets retinal neurons using an electrode array implanted in the suprachoroidal space, between the choroid and scleral layers of the eye [11]. This implantation site has the advantages of surgical simplicity and long term stability [12] at the expense of increased distance from the retinal neuronal targets which may increase the charge levels required to elicit percepts and limit spatial resolution [13], [14].

Whilst preclinical studies can provide some insight into the specifications required for a neurostimulator that will be efficacious for a suprachoroidal retinal prosthesis [15]–[18],

[†] The Bionic Vision Australia Consortium consists of five member organizations (Centre for Eye Research Australia, Bionics Institute, NICTA, University of Melbourne and University of New South Wales) and three partner organizations (The Royal Victorian Eye and Ear Hospital, National Vision Research Institute of Australia and the University of Western Sydney). For this publication, the consortium members consist of P. J. Allen, L. N. Ayton, T.-L. E. Brawn, R. Briggs, A. N. Burkitt, O. Burns, P. N. Dimitrov, R. H. Guymer, W. Heriot, C. D. Luu, M. McCombe, M. E. McPhedran, R. E. Millard, A. Mueller, D. A. X. Nayagam, N. L. Opie, T. Perera, A. L. Saunders, P. M. Seligman, R. K. Shepherd, M. N. Shivdasani, J. Villalobos, C. E. Williams and J. Yeoh.

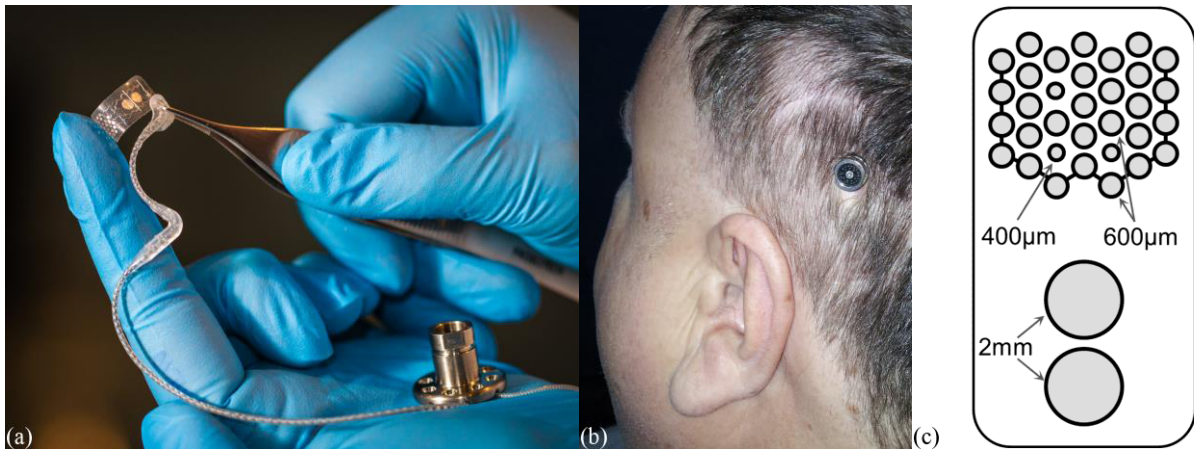

FIGURE 1. Prototype suprachoroidal retinal prosthesis with percutaneous connector. (a) An electrode array (top left) designed to be implanted in the suprachoroidal space of the eye is connected to a percutaneous connector (bottom right) via a leadwire. Photo provided by D A X Nayagam. (b) The percutaneous connector is implanted behind the ear and provides an external electrical connection to the implanted electrodes. (c) A schematic illustration of the electrode layout of the array (not to scale). Twenty stimulating electrodes ($17 \times 600\mu\text{m}$ and $3 \times 400\mu\text{m}$ diameter) are arranged in a hexagonal grid, which is surrounded by thirteen interconnected $600\mu\text{m}$ diameter electrodes that form a guard-ring return. The array also includes two large return electrodes (2mm diameter). An additional return electrode (not shown) is implanted subcutaneously close to the percutaneous connector.

there are still many unknowns. For example, the electrical properties of the electrode-tissue interface and the charge levels required to elicit a neural response are undetermined for degenerated human retina. To address this, BVA has developed a prototype 24-electrode suprachoroidal implant with a percutaneous connector (Fig. 1) [11]. The percutaneous connector provides a direct electrical connection to each electrode in the device, allowing maximum flexibility in the stimuli applied. This enables the stimulation parameter space to be thoroughly explored using an external stimulator and the performance of a suprachoroidal implant to be evaluated. The results can then be used to inform the design of future devices, including fully implanted systems.

To minimize the risk of harmful effects of stimulation, it is essential that the external neurostimulator adheres with established design principles of safe electrical stimulation. These include the use of charge-balanced biphasic pulses [19], post-stimulus electrode shorting and output coupling capacitors to maintain charge recovery [20], [21], charge limits and charge density limits to prevent damaging stimulation being delivered [22]–[24], as well as appropriate electrical isolation in accordance with IEC60601-1 [25]. The use of constant-current stimulation pulses is also required to ensure that changes in impedance at the electrode-tissue interface are intrinsically compensated for, allowing precisely predetermined amounts of charge to be reliably delivered [2].

To fully exploit the unrestricted access to the electrodes provided by the percutaneous connection, a highly configurable neurostimulator is required. The stimulus pulse parameters (Fig. 2) must have appropriately wide ranges and a resolution that allows flexibility in the values used. Preclinical studies investigating suprachoroidal stimulation using a feline model have used phase widths ranging from $100\mu\text{s}$ to 3ms , with $300\text{--}1200\mu\text{s}$ recommended as optimal for eliciting visual responses whilst balancing charge and

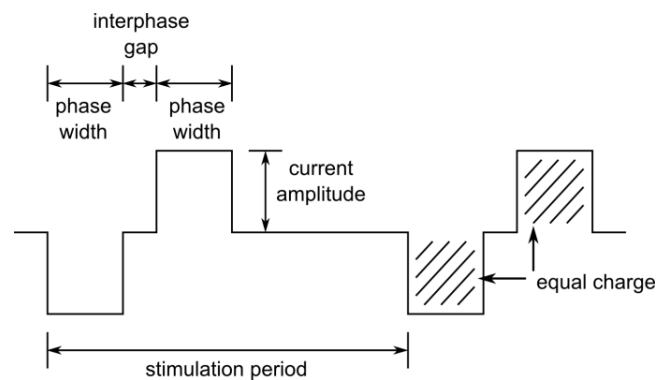

FIGURE 2. Charge-balanced, constant-current biphasic stimulus pulse parameters.

current requirements [17]. As shorter phase widths require larger currents to deliver a given amount of charge, the neurostimulator must have an adequately high maximum output current. For example, a biphasic pulse with 500nC per phase, a charge level that has been required in some preclinical suprachoroidal stimulation studies [15], [18], would require a current of 5mA when using a $100\mu\text{s}$ phase width. The compliance voltage, the maximum voltage that can be produced to maintain delivery of a specified constant current, must also be sufficiently high. The compliance voltage required is dependent on the current delivered, the phase width and the electrode impedance, defined as the peak voltage of a biphasic pulse divided by the stimulus current amplitude [26]. A preclinical study using suprachoroidal electrodes of the same size as those used in this study ($600\mu\text{m}$ diameter) recorded electrode impedances between $11\text{--}15\text{k}\Omega$ using $75\mu\text{A}$ pulses with a $25\mu\text{s}$ phase width [27], suggesting a high voltage compliance will be required to use large currents. Other preclinical studies that used smaller,

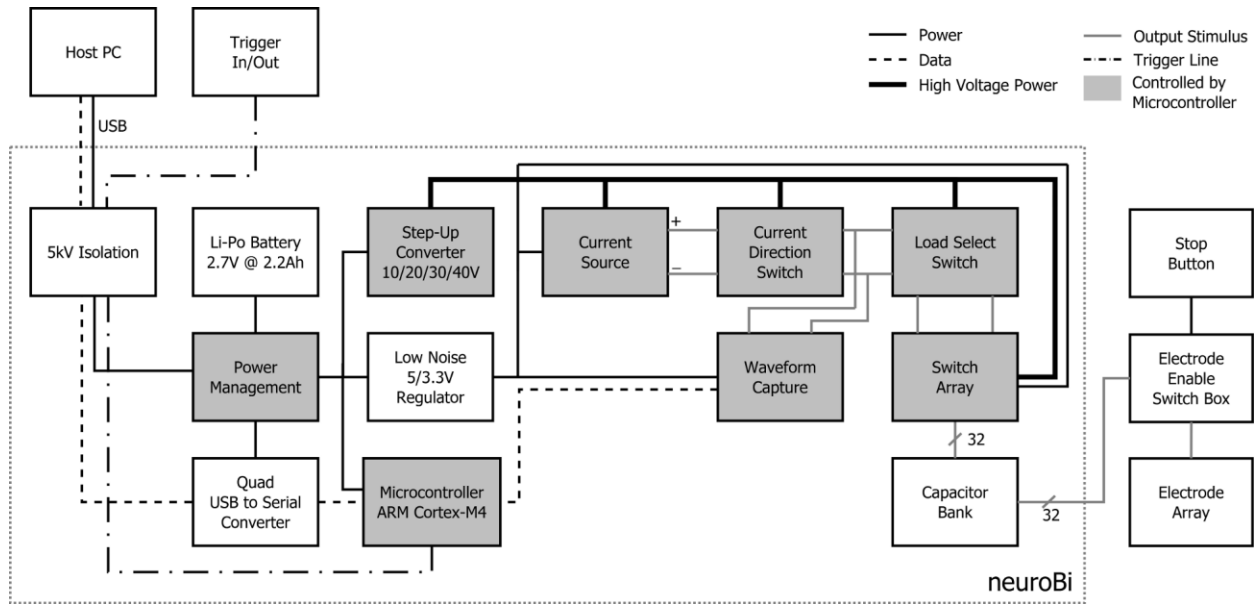

FIGURE 3. Block diagram illustrating the major functional components of neuroBi and its place within a typical patient-testing setup.

higher-impedance electrodes ($\leq 395\mu\text{m}$ diameter) were performed using a stimulator with 24V voltage compliance. This stimulator was capable of eliciting visual responses using currents up to 2mA [15]–[18]. Consequently, a maximum compliance voltage of 40V is considered a suitable requirement, as it provides headroom for using short ($\leq 100\mu\text{s}$) phase widths and higher currents. A high degree of electrode configurability is also required to enable delivery of stimuli via various combinations of active and return electrodes; for example, a configuration using a single remote return electrode has been theorized to have different current spread properties than a configuration using multiple nearby electrodes as the return, which may affect percept appearance [16], [28]. Additionally, it is desirable for the external stimulator to be small and portable to facilitate stimulation whilst the patient is mobile.

Whilst there are various commercial neurostimulators available from companies such as Natus Neurology Inc. (Grass Technologies), Digitimer Limited, and FHC Incorporated, they generally have limitations in one or more of the specifications required. For example, the Grass S12X Cortical Stimulator (Natus Neurology Inc., USA) is a constant-current biphasic stimulator that can deliver up to 15mA and has a high degree of electrode configurability when combined with an ESAx Electrode Switching Array (Natus Neurology Inc., USA). However, the resolution of the pulse parameters is restricted to a small number of steps, the frequency range is limited to 2-100Hz and the current accuracy is only specified for loads of 100-2000 Ω [29]. The need to combine separate modules and the need for a mains power supply also limit the portability of the system. Taking into account all of the requirements, there appears to be no appropriate neurostimulator available for use in evaluating a

suprachoroidal implant, and consequently a custom solution was required.

This article details the design of a highly configurable, high compliance voltage, 32-electrode neurostimulator, known as neuroBi, and its application in determining whether visual percepts could be elicited using a prototype suprachoroidal electrode array implanted in one patient with approximately 20 years of light perception vision only due to retinitis pigmentosa. The configurability of neuroBi together with its capability to deliver stimulation across a wide range of parameters make it suitable not only for use with a prototype suprachoroidal electrode array, but also for many other clinical applications, including prediction and suppression of epileptic seizures through stimulation of subdural electrode arrays [30], [31] and deep brain stimulation.

II. METHODS

A. SYSTEM DESIGN

The major functional components of neuroBi and its place within a typical patient-testing setup are illustrated in Fig. 3. Under the control of a host personal computer (PC) and an embedded microcontroller, neuroBi is designed to deliver sequences of highly adjustable (table 1) charge-balanced, constant-current biphasic pulses to any combination of outputs connected to an implanted electrode array. The pulses are generated using a single current source whose direction is switched to reverse the polarity of the stimulating electrodes and produce the alternating phases. A switch array connects the pulse generation circuitry to the desired output configuration via coupling capacitors.

A maximum phase width of 3ms was chosen to be consistent with preclinical experiments [17]. The maximum

TABLE 1. neuroBi Stimulus Parameters.

Current Amplitude	0-10mA (1 μ A steps)
Phase Width	20 μ s-3ms (1 μ s steps)
Interphase Gap	20 μ s-3ms (1 μ s steps)
Stimulation Period ^a	160 μ s-5s
Number of Outputs	32
Electrode Configurability	Arbitrary
Nominal Compliance Voltage	Selectable 10/20/30/40V

^adependent on phase width and interphase gap used

interphase gap was also set to 3ms to allow gaps equal to the phase width to be used. A maximum current amplitude of 10mA was chosen to allow the use of narrow phase widths (e.g. 100 μ s). The maximum compliance voltage was set to 40V, but was made adjustable under software control to allow lower levels to be used if high voltages were not required. Using a lower compliance voltage setting minimizes the risk of high voltages accidentally being applied to tissue and also reduces the power consumption of the device by lowering the supply rails. A resolution of 1 μ A and 1 μ s was used to maximize the flexibility in the selectable values.

The connection to the host PC is via Universal Serial Bus (USB), which provides power and communication to neuroBi to configure device settings, control the delivery of stimuli and to record data. Communication messages consist of packets of bytes, which include a start byte to mark the beginning of a message, a command identification byte specifying the message function, a number of data bytes and a checksum byte for message verification. The checksum used is a 2's-complement modular sum. External trigger lines are also provided by neuroBi, which can be used to initiate delivery of preloaded stimuli and to indicate when pulses are being delivered.

The power and data lines of the USB connection and the trigger lines are isolated within neuroBi to 5kV. The isolated USB data line is then converted into four universal asynchronous receiver/transmitters (UART) using a quad serial-to-USB converter (FT4242H, FTDI Chip, UK). This allows the host PC to communicate with neuroBi over four serial ports, with different ports used for sending command messages, debug information, stimulus current measurements, and voltage waveform data recorded by neuroBi. The four UARTs are connected to the microcontroller (Kinetic K40 MK40X256VLQ100, Freescale Semiconductor, USA), which is responsible for controlling the function of neuroBi, including handling communication, managing power settings, buffering sequences of pulses for delivery, and coordinating stimulus generation. The isolated trigger lines are also connected to the microcontroller.

The isolated USB power is routed through to a power management chip (LTC3567, Linear Technology, USA) that supplies power to the system and opportunistically charges a Lithium Polymer battery. The battery is primarily used to ensure safe shutdown in the event that USB connectivity is unexpectedly lost, but can also be used as the sole power supply for the device to facilitate ambulatory applications by

eliminating the need for a portable computer (e.g. laptop, tablet, or single-board computer) to power the device. The power management chip generates a 3.3V regulated supply that provides power to the microcontroller and communication circuitry, and an unregulated supply that feeds a step-up converter and two low-noise 5/3.3V DC supplies. The step-up converter is capable of generating the high-voltage supply rail required to power the pulse generation and routing circuitry with a software-controllable compliance voltage of 10, 20, 30, or 40V.

The use of a single switched current source to generate the stimulus pulses has the advantage of intrinsic charge matching for symmetric biphasic pulses, as the same circuitry is used to produce both phases. It also has the benefit of requiring only a single high-voltage supply, as opposed to the dual supplies that would be required if a source and sink were used. The design of a precision current source with a compliance voltage of up to 40V, a slew rate sufficient for generating microsecond-scale pulses, as well as high efficiency and an output impedance high enough to ensure less than 1% variation in current across tissue loads, required careful consideration. A discrete bipolar junction transistor (BJT) based topology was used as it could be tailored to meet these specifications, at the expense of increased design complexity. In comparison, operational amplifier based topologies such as the Improved Howland current pump used in some other neurostimulators [32], [33], are limited by the capabilities of the operational amplifier used. A chip that could meet the slew rate, supply rail and output offset requirements for this application was not identified.

A linearized BJT and current mirror were used to create the current source (Fig. 4). An Improved Wilson current mirror [34] was used to achieve high output impedance and to mitigate error due to finite base current. Additional matched transistors are connected in parallel on the output side to provide accurate current scaling. This also improved power efficiency by minimizing the total branch current required for a given output current. Matched emitter degeneration resistors were also used to improve BJT beta matching and the output impedance of the current source.

The current source is connected to quad high-voltage single-pole single-throw switches (ADG5412, Analog Devices, USA), which are used to interchange the direction of current flow to produce biphasic pulses. A high voltage 4-channel multiplexer (MUX) (ADG5404, Analog Devices, USA) is then used to route the current to either the switch array or to one of three low temperature coefficient resistive loads that are used to verify the amplitude and for calibration. A high input impedance waveform capture circuit comprising a fully differential amplifier and a 16-bit analog-to-digital converter (AD7694, Analog Devices, USA) is also connected across the output lines of the current direction switches. This is used for current-source calibration and to measure the voltage waveform across the output electrodes during stimulation with a sampling rate of 100 kilosamples per second.

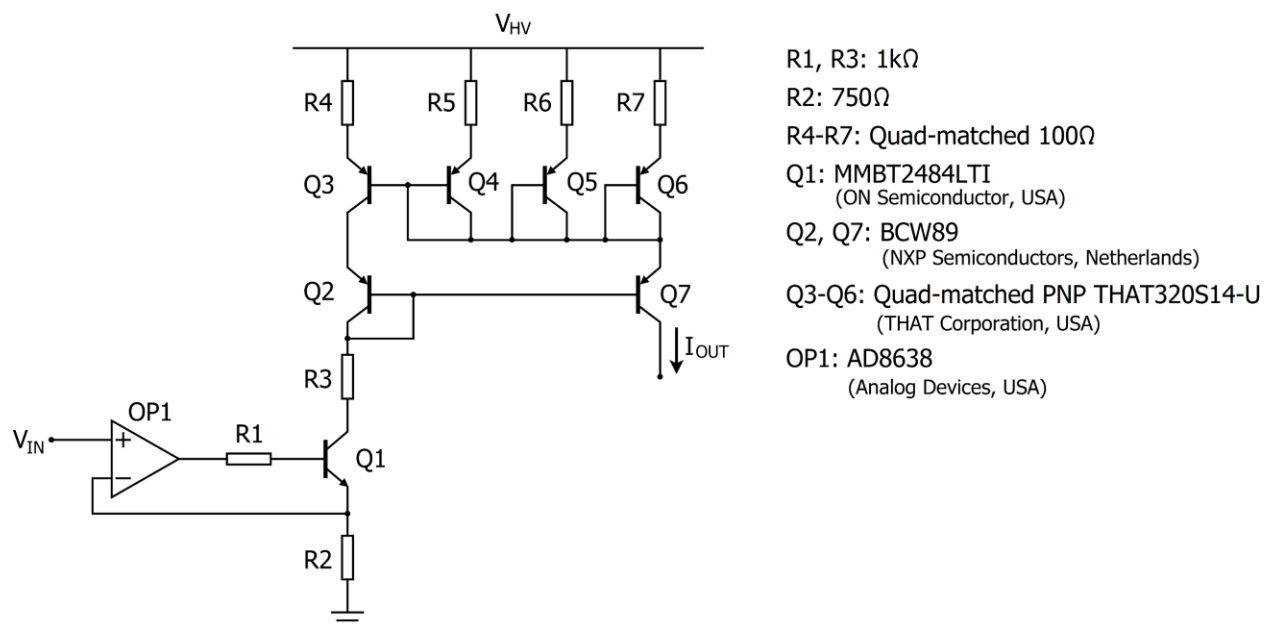

FIGURE 4. Current source used to generate stimulus pulses, consisting of a linearized BJT and an Improved Wilson current mirror with additional current scaling.

The switch array is used to route the current pulses to the electrode outputs. Each output can be individually connected as either an active or return line using high-voltage 4-channel MUXs (ADG5204, Analog Devices, USA). This facilitates the unrestricted selection of electrode configurations for stimulation. When not being used for stimulation, each output can be set to be open circuit or connected to a common point. The common-point connection allows electrodes to be shorted together after stimulation, which is an established method for removing residual charge in tissue due to charge imbalance [21]. All high-voltage switches and MUXs used in neuroBi feature trench isolation to prevent latch-up due to electrode voltages beyond supply rails.

As stimulation safety was of paramount importance to the design of neuroBi, coupling capacitors are used on each output for protection against residual direct current (DC) due to leakage and charge imbalance [21]. Including capacitors also protects tissue in the event that an output stage fails catastrophically by blocking DC from being applied to the electrodes. Choosing an appropriate capacitor size is a compromise between compliance voltage reduction and physical size. A 10 μ F ceramic (X7R) capacitor was chosen as for a 500nC per phase pulse, a stimulation level which has been used preclinically to measure evoked responses with a suprachoroidal array [15], [18], the compliance voltage reduction is only 50mV whilst using a reasonably sized surface-mount package (1210).

The outputs of neuroBi are connected to the patient's implanted electrode array via an electrode enable switch box. This additional safety feature allows the electrodes to be individually connected to or disconnected from neuroBi.

The electrode enable switch box consists of an array of momentary push buttons each connected to a low-voltage normally-open relay. When the button for a particular electrode is pressed, power is supplied to the coil of the relay by a simple toggle on/off circuit and the connection is established. An LED in the push button is powered through a second pole of the relay to indicate that the electrode is connected. Buttons are also included that concurrently connect and disconnect all electrodes. A 'stop' button is connected to the electrode enable box which removes the power from the relays when actuated, causing them to revert to the open state and completely disconnecting the stimulator. This allows the patient or researcher to immediately cut off all stimulation in the event that any discomfort or other unexpected effects occur.

To deliver a stimulus, commands are first sent from the host PC to load neuroBi with the desired pulse parameters (phase width, interphase gap, rate) and electrode configuration (Fig. 5). Up to 256 different stimulus parameter sets and 255 electrode configurations can be loaded. Before each parameter set or electrode configuration is stored, the nominated values are checked against defined limits and any unacceptable values are rejected. Commands can then be sent to trigger the delivery of a stimulus using a particular parameter set and electrode configuration with a specified current amplitude and number of repetitions. Alternatively, stimuli can be buffered for delivery as a sequence. Prior to any stimulus being delivered, the charge per phase is calculated within neuroBi and compared to a safe limit. Any stimuli that exceed the charge limit are not delivered. The user can set the charge limit to an

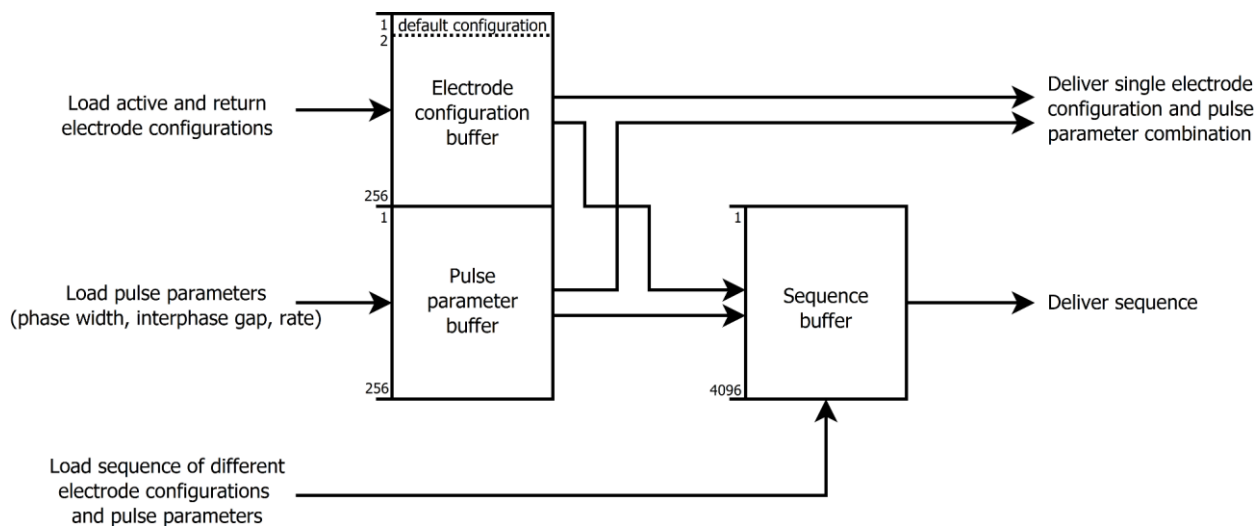

FIGURE 5. Stimulus delivery process. Electrode configurations and pulse parameters are first loaded into neuroBi. Stimuli comprising different electrode configurations and pulse parameters can then be delivered, either one at a time or in a sequence.

appropriate value by sending a command message from the host PC.

III. RESULTS

A. FUNCTIONAL & SAFETY TESTING

Prior to neuroBi being used clinically with patients, extensive functional and safety testing was performed both internally and by independent external engineers. Stimulation pulses were delivered to a variety of test loads using a range of parameters, with the resulting output waveforms verified for accuracy (Fig. 6). From these waveforms the current output was measured to be accurate to within 2% for currents greater than $100\mu\text{A}$. The output impedance and voltage compliance were characterized for a range of output current levels (Fig. 7). The charge injection, the amount of unwanted charge injected into the output current path due to stray capacitance within the switching integrated circuits, was also measured and found to be less than 1nC .

The residual DC resulting from stimulation of the suprachoroidal electrode array using neuroBi was measured *in vitro* for a range of pulse parameters under various load conditions. The DC was found to be less than 15nA in all cases. Preclinical studies establishing a safe limit for residual DC in a suprachoroidal retinal prosthesis have not been reported. However, DC levels of less than 100nA have been shown to cause no damage when applied to the cochlea [21]. Based on this data the device was considered safe and highly unlikely to cause any tissue damage.

A risk analysis was performed in accordance with ISO 14971, covering failure modes and the use of neuroBi with human subjects. Both neuroBi and the electrode enable box passed electrical safety tested to Australian Standard (AS) 3551 (2004) and the electromagnetic emissions of neuroBi were found to conform with AS CISPR11 (2011). Additionally, neuroBi passed

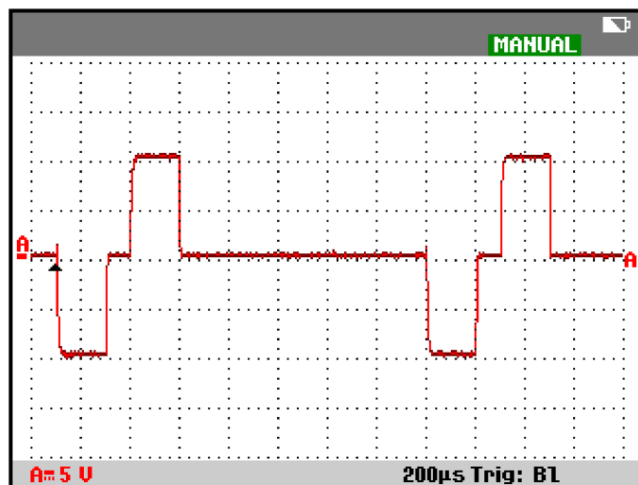

FIGURE 6. Stimulation waveform recorded across a $10\text{k}\Omega$ test load using a Fluke 190-204 Scopemeter (Fluke Corporation, USA). The measured pulse parameters correspond with the defined settings of $200\mu\text{s}$ phase width, $100\mu\text{s}$ interphase gap, 1.5ms stimulation period and 1mA current amplitude.

electrostatic discharge immunity testing in accordance with AS 61000.4.2 (2002).

B. PATIENT TESTING

The initial application for neuroBi was to determine whether visual percepts could be elicited in one patient with profound vision loss using a suprachoroidal electrode array. Measurement of electrode impedances was also required to verify connectivity and to inform compliance voltage requirements.

Following approval from the Royal Victorian Eye & Ear Hospital Human Research Ethics Committee and trial registration (www.clinicaltrials.gov, trial # NCT01603576), one patient with profound vision loss due to retinitis

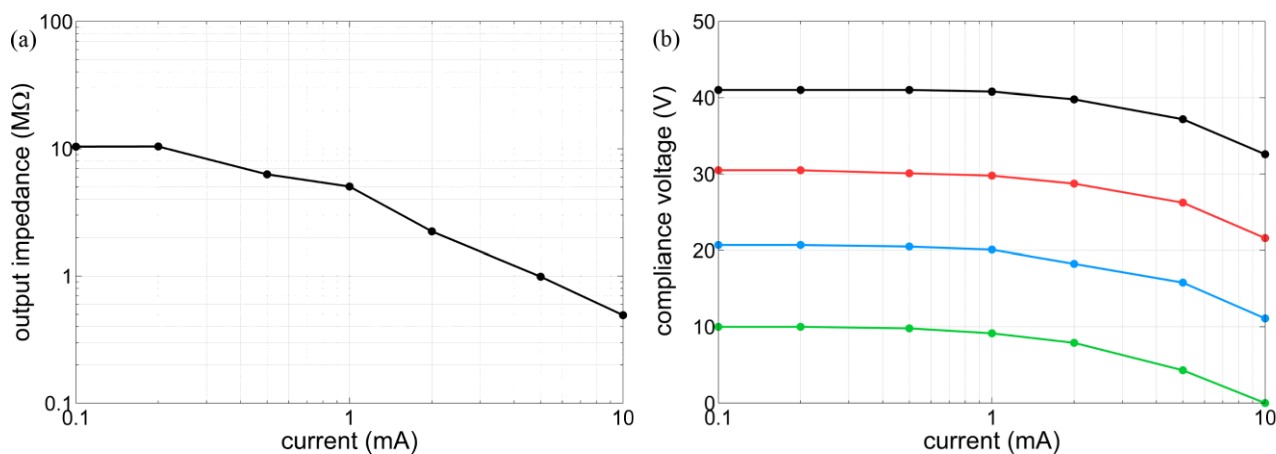

FIGURE 7. (a) Measured output impedance as a function of output current. (b) Measured compliance voltage as a function of output current using a 3ms phase width (worst case) with nominal settings of 10, 20, 30, and 40V. Voltage compliance is reduced for long phase widths and large currents due to charging of the output coupling capacitors.

pigmentosa was selected through a clinical screening process. The selected patient was a 52 year old female with rod-cone dystrophy and approximately 20 years of light perception only vision. Informed consent was obtained in accordance with the Declaration of Helsinki. Following preliminary testing with this patient, two additional patients were scheduled to be implanted and tested at a later date. Further details on patient selection are reported elsewhere [35].

The suprachoroidal electrode array (Fig. 1) consisted of twenty platinum discs ($17 \times 600\mu\text{m}$ and $3 \times 400\mu\text{m}$ diameter) arranged in a hexagonal grid within a silicone substrate. These electrodes were intended primarily for use as active current delivery sites. The implant also included thirteen interconnected $600\mu\text{m}$ platinum discs and two 2mm platinum discs for use as return electrodes. Each electrode was individually connected via a helical platinum/iridium wire to the pins of a titanium percutaneous connector, which was implanted behind the patient's ear. The lead wire and electrode array were tunneled subcutaneously to the orbit and inserted into the suprachoroidal space through a scleral incision. An additional electrode was also implanted adjacent to the percutaneous connector for use as a remote return. Details of the surgical procedure have been published previously [11], [35], [36].

Stimulation of the electrodes using neuroBi was performed after approximately 8 weeks healing time. Stimulus delivery was controlled using a purpose-built graphical user interface, called EyeSee, running on the host PC. EyeSee was responsible for managing experimental procedures, communicating with neuroBi via a custom device driver and applying additional safety features, including enforcing charge limits. Ideally, the maximum charge that can be safely delivered using a suprachoroidal array would be defined through preclinical safety studies. However, whilst chronic suprachoroidal stimulation safety studies have been performed, they are yet to define a safe charge limit

precisely [27]. In the absence of more appropriate data, the Shannon model of safe levels of electrical stimulation [23] with a k value of 1.85, as shown in [24], was used to define maximum charge limits. If the specified charge per phase exceeded the relevant limit, 447nC for a $600\mu\text{m}$ electrode and 298nC for a $400\mu\text{m}$ electrode, EyeSee would not deliver the stimulus. The compliance voltage required for a given stimulus was also estimated before stimulus delivery using the nominated current amplitude and measured electrode impedances to ensure it was within range.

Electrode impedances were measured using biphasic pulses and were defined as the voltage at the end of the first phase divided by the current amplitude (Fig 8). The voltage waveforms were recorded using the neuroBi waveform capture circuit and an average of 50 pulses was used to calculate the impedance for each electrode. A common-ground configuration was used, where one active electrode was stimulated against all others. In this configuration, the parallel connection of multiple return electrodes created a low-impedance path, so that the recorded impedance value was dominated by the impedance of the individual active electrode.

Stimulation parameters of $500\mu\text{s}$ phase width, 20 μs interphase gap, $75\mu\text{A}$ current amplitude and 500pps rate, were chosen for measuring electrode impedances, based on the results of preclinical studies [15], [17]. Using these parameters, impedances were measured to be 16.5-20k Ω ($600\mu\text{m}$ electrodes), 23.5-25.5k Ω ($400\mu\text{m}$ electrodes) and 2.5-5.5k Ω (return electrodes). Two electrodes were initially detected as open circuit, but those faults were traced to poor contacts within the percutaneous connector that were rectified later by replacing an externally accessible component. Subsequently, all electrodes were available for use in stimulation. The $600\mu\text{m}$ impedances measured were approximately 5k Ω higher than those recorded preclinically [27], however this can be attributed to different phase widths being

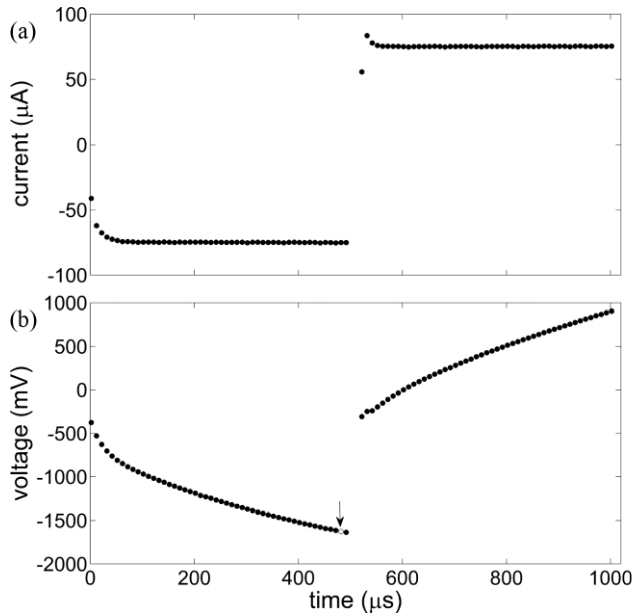

FIGURE 8. Example current and voltage waveforms used to measure electrode impedance. (a) Current waveform measured by stimulating a test load and dividing the recorded voltage samples by the known resistance. (b) Voltage waveform recorded from an implanted $600\mu\text{m}$ electrode using a common-ground return. Both waveforms were recorded using the neuroBi waveform capture circuit and are the average of 50 pulses. Filled circles = averaged samples, open circle (marked by arrow) = voltage data point used to calculate impedance. Samples were not recorded during the interphase gap.

used ($500\mu\text{s}$ vs $25\mu\text{s}$) and differences between a sighted feline model and a degenerate human retina.

Efficacy in eliciting visual percepts was assessed using perceptual threshold measurements. An iterative stair-case procedure was used, whereby stimuli with progressively increasing charge per phase were delivered until a percept was reported by the subject. The charge per phase was then reduced until the percept was no longer observed. This process was repeated until 8 turning points had been recorded, with the average of the last six turning points used as the perceptual threshold. If the charge per phase increased to the safe charge limit, the procedure was aborted and the electrode was considered to be unable to elicit a visual percept using the stimulation parameters selected. Perceptual threshold values were recorded in units of nC and also in dB re 10nC, as perceived brightness is expected to be proportional to the logarithm of stimulus intensity [37]. Further details on the threshold procedure are reported elsewhere [38].

The threshold-estimating procedure was performed on nineteen electrodes, with one $600\mu\text{m}$ electrode excluded as it was apparently open-circuit due to a poor contact in the percutaneous connector. Based on results of preclinical studies [15]–[17], stimulation parameters of $500\mu\text{s}$ phase width, $20\mu\text{s}$ interphase gap, 50pps rate, and 0.5s duration were chosen with a monopolar electrode configuration, where an individual electrode was stimulated against one of the 2mm intraocular returns. Charge per phase was modulated by adjusting the current amplitude. Visual percepts were successfully elicited on all $600\mu\text{m}$ electrodes tested, with

threshold levels in the range 100–370nC (20–31.4dB). The safe charge limit was reached before a perceptual threshold could be obtained for two of the $400\mu\text{m}$ electrodes, whilst the other $400\mu\text{m}$ electrode produced a percept with a threshold of 190nC (25.6dB). Two $600\mu\text{m}$ electrodes were also tested using a common-ground configuration, producing perceptual thresholds of 176nC (24.9dB) and 360nC (31.1dB).

The reported appearance of phosphenes varied depending on the electrode stimulated. Shapes varied from simple ovals filled with cream-grey light, to complex shapes with multiple light and dark regions [39]. The location of phosphenes in the visual field was also reported to vary in a manner consistent with the layout of the electrode array. The return electrode configuration did not appear to strongly affect phosphene appearance. Detailed characterization of phosphene appearance will be the subject of a future publication.

IV. DISCUSSION

An innovative neurostimulator, neuroBi, has been described. Preliminary clinical test results have shown it to be effective in eliciting visual percepts in a profoundly vision-impaired subject with approximately 20 years of light perception vision only, implanted with a suprachoroidal electrode array. The final device is a highly configurable neurostimulator in a relatively small form factor, with dimensions of $170\text{mm} \times 130\text{mm} \times 55\text{mm}$ and weight of 800g (Fig. 9).

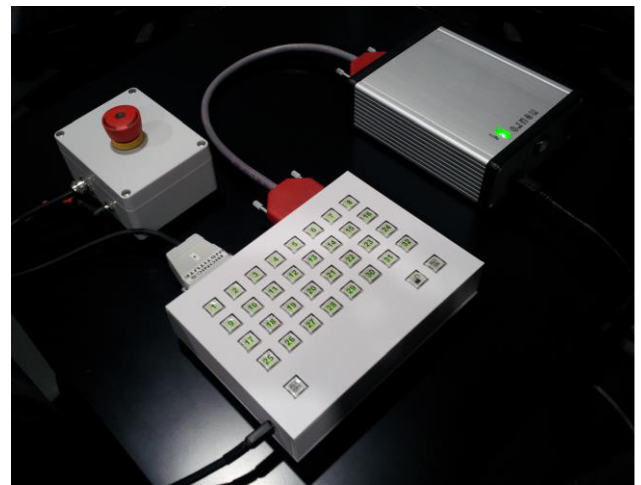

FIGURE 9. Photo of neuroBi (top right), electrode enable switch box (bottom) and 'stop' button (top left).

By stimulating individual electrodes with neuroBi, it was possible to elicit distinct phosphenes using a suprachoroidal implant. The perceptual thresholds are approximately 2 times higher than those measured using chronic epiretinal stimulation in humans [38], however higher thresholds are expected as a suprachoroidal implant is further from the retinal stimulation targets. These results suggest that the suprachoroidal space is a viable implantation site for a retinal prosthesis.

Further work is required to characterize the phosphenes elicited and to determine how they can be used to

functionally improve the patient's vision. Following this successful preliminary testing, two additional patients have been implanted with the suprachoroidal device and all three patients have been subject to weekly psychophysics sessions. Psychophysics testing is being performed to determine the optimum stimulation parameters for a suprachoroidal retinal prosthesis [38]; to characterize the appearance and location of the visual percepts elicited; and to investigate how to build useful visual information by stimulating multiple electrodes closely in time. A head-mounted video camera has also been integrated with neuroBi and the host PC to provide real-time stimulation based on the visual scene in front of the patient. This has allowed standard visual acuity tests to be performed and enabled patient performance to be assessed in a number of activities of daily living, such as navigation and object recognition [35].

The initial results obtained suggest that the full capabilities of neuroBi will be required to undertake psychophysics testing with the prototype suprachoroidal electrode array. The threshold levels measured (100–370nC) are approaching the defined safe charge limit for a 600 μ m electrode (447nC). Subsequently, stimuli up to the limit will be required to be able to stimulate at levels above threshold. The safe charge limit corresponds to 894 μ A for a 500 μ s phase width; however, if shorter phase widths are used, higher currents will be required. For example, if a 100 μ s phase width is used the safe limit would correspond to 4.47mA, which is still well within the capabilities of neuroBi. The electrode impedances measured suggest that the highest compliance voltage setting (40V) will also be required. Using Ohm's law as a crude estimator of compliance voltage requirements, a series combination of a 400 μ m electrode (up to 25.5k Ω) and a return electrode (up to 5.5k Ω), as used in a monopolar configuration, could require up to 31V when stimulated at 1mA. Whilst it is not expected that the electrode-tissue interface will behave as a purely resistive conductor, this approximation illustrates that a high voltage compliance capability may be required in some conditions.

To the authors' knowledge, the capabilities of neuroBi in terms of current output, compliance voltage, electrode configurability and portability are not achievable with commercially available external or implantable stimulators. This flexibility of neuroBi will be used with psychophysics testing to explore and refine the stimulator specifications required for a suprachoroidal implant. These can then be used to inform production of a fully implantable stimulator device that is designed to meet those requirements.

The applications for neuroBi are not limited to suprachoroidal retinal prostheses. Its versatility makes it suitable for use in stimulating any neural interface with an externally accessible connection. Additionally, with relatively minor modifications, the switch array can be expanded to 128 channels and setup to route electrode connections to external recording equipment when not being used for stimulation. Currently, neuroBi is being used preclinically to test spatiotemporally complex patterns of stimulation that

have been proposed for suppressing epileptic seizures [40] and is being integrated into an existing closed-loop system for epileptic seizure detection and suppression [30], [40]. It is also intended that neuroBi will be used in a seizure prediction system that probes cortical excitability using subdural electrodes [31], for cortical mapping prior to surgical resection, and in a closed-loop deep brain stimulation system.

Future work may include the development of stimulators capable of outputting arbitrary waveforms. Whilst the effectiveness of symmetric biphasic waveforms (as in Figure 2) for neurostimulation is well established, other waveforms, such as sine waves [41] or asymmetric biphasic pulses [42], [43], may provide benefits such as greater neuronal selectivity and/or reduced perceptual thresholds. A stimulator with arbitrary waveform capabilities will allow these concepts to be evaluated, including whether they are safe for chronic use. Arbitrary waveform generation is feasible with neuroBi, requiring only changes to the firmware.

Development of neurostimulators with multiple independent current sources is another area for further work. The capability to simultaneously deliver current to multiple electrodes in a controlled manner would allow advanced stimulation strategies to be applied, such as current steering which has the potential to improve the spatial resolution of retinal prostheses [44], [45]. A device with the necessary capabilities is required to evaluate the safety and efficacy of such strategies.

V. CONCLUSION

The initial application for neuroBi was to evaluate the capabilities of a suprachoroidal retinal prosthesis in visually impaired humans. Using neuroBi, reproducible phosphenes were successfully elicited in one patient with light perception vision only, suggesting that the suprachoroidal space is a viable implantation site for a retinal prosthesis. The results obtained from subsequent experiments performed using neuroBi will guide the design of next-generation devices and progress the development of a commercially viable visual prosthesis that can provide functional vision to the profoundly vision-impaired. The configurability of neuroBi also makes it suitable for use in a number of other clinical neurostimulation applications and it is already being used to develop treatments for epilepsy and other neurological disorders. As such, neuroBi is a valuable tool for translating clinical research into therapeutic devices.

ACKNOWLEDGMENT

The authors wish to thank the three patients who bravely and altruistically volunteered to be implanted with the prototype suprachoroidal retinal implant and generously donated their time for psychophysics testing. They would also wish to acknowledge Alan Lai who provided advice regarding epilepsy applications for neuroBi, Thushara Perera who developed the EyeSee program and Rodney Millard who developed the custom device driver, including the impedance measurement procedure.

The suprachoroidal array and lead wire were designed by the Bionics Institute using research components supplied by Cochlear Ltd (Sydney, Australia).

REFERENCES

- [1] A. Prochazka, V. K. Mushahwar, and D. B. McCreery, "Neural prostheses," *J. Physiol.*, vol. 533, pp. 99–109, May 2001.
- [2] P. H. Peckham and J. S. Knutson, "Functional electrical stimulation for neuromuscular applications," *Annu. Rev. Biomed. Eng.*, vol. 7, pp. 327–360, Aug. 2005.
- [3] C. Halpern, H. Hurlig, J. Jaggi, M. Grossman, M. Won, and G. Baltuch, "Deep brain stimulation in neurologic disorders," *Parkinsonism Rel. Disorders*, vol. 13, no. 1, pp. 1–16, 2007.
- [4] G. Clark, Y. C. Tong, and J. F. Patrick, *Cochlear Prostheses*. Edinburgh: Churchill Livingstone, 1990.
- [5] R. K. Shepherd, M. N. Shivdasani, D. A. X. Nayagam, C. E. Williams, and P. J. Blamey, "Visual prostheses for the blind," *Trends Biotechnol.*, vol. 31, no. 10, pp. 562–571, 2013.
- [6] G. S. Brindley and W. S. Lewin, "The sensations produced by electrical stimulation of the visual cortex," *J. Physiol.*, vol. 196, no. 2, pp. 479–493, 1968.
- [7] W. H. Dobbelle and M. G. Mladejovsky, "Phosphenes produced by electrical stimulation of human occipital cortex, and their application to the development of a prosthesis for the blind," *J. Physiol.*, vol. 243, no. 2, pp. 553–576, 1974.
- [8] E. Zrenner *et al.*, "Subretinal electronic chips allow blind patients to read letters and combine them to words," *Proc. R. Soc. B*, Nov. 2010, doi: 10.1098/rspb.2010.1747.
- [9] T. Fujikado *et al.*, "Testing of semichronically implanted retinal prosthesis by suprachoroidal-transretinal stimulation in patients with retinitis pigmentosa," *Invest. Ophthalmol. Vis. Sci.*, vol. 52, no. 7, pp. 4726–4733, 2011.
- [10] M. S. Humayun *et al.*, "Interim results from the international trial of Second Sight's visual prosthesis," *Ophthalmology*, vol. 119, no. 4, pp. 779–788, 2012.
- [11] A. L. Saunders *et al.*, "Development of a surgical procedure for implantation of a prototype suprachoroidal retinal prosthesis," *Clin. Experim. Ophthalmol.*, vol. 42, no. 7, pp. 665–674, Sep./Oct. 2014.
- [12] J. Villalobos *et al.*, "A wide-field suprachoroidal retinal prosthesis is stable and well tolerated following chronic implantation," *Invest. Ophthalmol. Vis. Sci.*, vol. 54, no. 5, pp. 3751–3762, 2013.
- [13] H. Kanda, T. Morimoto, T. Fujikado, Y. Tano, Y. Fukuda, and H. Sawai, "Electrophysiological studies of the feasibility of suprachoroidal-transretinal stimulation for artificial vision in normal and RCS rats," *Invest. Ophthalmol. Vis. Sci.*, vol. 45, no. 2, pp. 560–566, 2004.
- [14] Y. Yamauchi *et al.*, "Comparison of electrically evoked cortical potential thresholds generated with subretinal or suprachoroidal placement of a microelectrode array in the rabbit," *J. Neural Eng.*, vol. 2, no. 1, pp. S48–S56, 2005.
- [15] M. N. Shivdasani *et al.*, "Evaluation of stimulus parameters and electrode geometry for an effective suprachoroidal retinal prosthesis," *J. Neural Eng.*, vol. 7, no. 3, p. 036008, 2010.
- [16] R. Cicione *et al.*, "Visual cortex responses to suprachoroidal electrical stimulation of the retina: Effects of electrode return configuration," *J. Neural Eng.*, vol. 9, no. 3, p. 036009, 2012.
- [17] S. E. John *et al.*, "Suprachoroidal electrical stimulation: Effects of stimulus pulse parameters on visual cortical responses," *J. Neural Eng.*, vol. 10, no. 5, p. 056011, 2013.
- [18] M. N. Shivdasani *et al.*, "Visual cortex responses to single- and simultaneous multiple-electrode stimulation of the retina: Implications for retinal prostheses," *Invest. Ophthalmol. Vis. Sci.*, vol. 53, no. 10, pp. 6291–6300, 2012.
- [19] J. C. Lilly, J. R. Hughes, E. C. Alvord, Jr., and T. W. Galkin, "Brief, noninjurious electric waveform for stimulation of the brain," *Science*, vol. 121, no. 3144, pp. 468–469, 1955.
- [20] N. de N. Donaldson and P. E. K. Donaldson, "When are actively balanced biphasic ('Lilly') stimulating pulses necessary in a neurological prosthesis? I. Historical background; Pt resting potential; Q studies," *Med. Biol. Eng. Comput.*, vol. 24, no. 1, pp. 41–49, 1986.
- [21] C. Q. Huang, R. K. Shepherd, P. M. Center, P. M. Seligman, and B. Tabor, "Electrical stimulation of the auditory nerve: Direct current measurement *in vivo*," *IEEE Trans. Biomed. Eng.*, vol. 46, no. 4, pp. 461–469, Apr. 1999.
- [22] D. B. McCreery, W. F. Agnew, T. G. H. Yuen, and L. Bullara, "Charge density and charge per phase as cofactors in neural injury induced by electrical stimulation," *IEEE Trans. Biomed. Eng.*, vol. 37, no. 10, pp. 996–1001, Oct. 1990.
- [23] R. V. Shannon, "A model of safe levels for electrical stimulation," *IEEE Trans. Biomed. Eng.*, vol. 39, no. 4, pp. 424–426, Apr. 1992.
- [24] D. R. Merrill, M. Bikson, and J. G. R. Jefferys, "Electrical stimulation of excitable tissue: Design of efficacious and safe protocols," *J. Neurosci. Methods*, vol. 141, no. 2, pp. 171–198, 2005.
- [25] *Medical Electrical Equipment—Part 1: General Requirements for Basic Safety and Essential Performance*, IEC Standard 60601-1, 2005.
- [26] S. E. John *et al.*, "An automated system for rapid evaluation of high-density electrode arrays in neural prostheses," *J. Neural Eng.*, vol. 8, no. 3, p. 036011, 2011.
- [27] D. A. X. Nayagam *et al.*, "Chronic electrical stimulation with a suprachoroidal retinal prosthesis: A preclinical safety and efficacy study," *PLoS One*, vol. 9, no. 5, p. e97182, 2014.
- [28] Y. T. Wong, S. C. Chen, J. M. Seo, J. W. Morley, N. H. Lovell, and G. J. Suaning, "Focal activation of the feline retina via a suprachoroidal electrode array," *Vis. Res.*, vol. 49, no. 8, pp. 825–833, 2009.
- [29] Grass Products. (Mar. 13, 2014). *S12X Cortical Stimulator*. [Online]. Available: <https://www.grasstechnologies.com/products/stimulators/s12x.html>
- [30] T. S. Nelson *et al.*, "Closed-loop seizure control with very high frequency electrical stimulation at seizure onset in the GAERS model of absence epilepsy," *Int. J. Neural Syst.*, vol. 21, no. 2, pp. 163–173, 2011.
- [31] D. R. Freestone *et al.*, "Electrical probing of cortical excitability in patients with epilepsy," *Epilepsy Behavior*, vol. 22, pp. S110–S118, Dec. 2011.
- [32] C. Hauptmann *et al.*, "External trial deep brain stimulation device for the application of desynchronizing stimulation techniques," *J. Neural Eng.*, vol. 6, no. 6, p. 066003, Dec. 2009.
- [33] C. J. Poletto and C. L. Van Doren, "A high voltage, constant current stimulator for electrocutaneous stimulation through small electrodes," *IEEE Trans. Biomed. Eng.*, vol. 46, no. 8, pp. 929–936, Aug. 1999.
- [34] B. L. Hart and R. W. J. Barker, "D.C. matching errors in the Wilson current source," *Electron. Lett.*, vol. 12, no. 15, pp. 389–390, 1976.
- [35] L. N. Ayton *et al.*, "First-in-human trial of a novel suprachoroidal retinal prosthesis," *PLoS One*, vol. 9, no. 12, p. e15239, 2014.
- [36] J. Villalobos *et al.*, "Development of a surgical approach for a wide-view suprachoroidal retinal prosthesis: Evaluation of implantation trauma," *Graefes Arch. Clin. Experim. Ophthalmol.*, vol. 250, no. 3, pp. 399–407, 2012.
- [37] G. T. Fechner, *Elements of Psychophysics*, vol. 1. New York, NY, USA: Holt, Rinehart and Winston, 1966.
- [38] M. N. Shivdasani *et al.*, "Factors affecting perceptual thresholds in a suprachoroidal retinal prosthesis," *Invest. Ophthalmol. Vis. Sci.*, vol. 55, no. 10, pp. 6467–6481, 2014.
- [39] P. Blamey *et al.*, "Psychophysics of a suprachoroidal retinal prosthesis," *Invest. Ophthalmol. Vis. Sci.*, vol. 54, p. 1044, Jun. 2013.
- [40] T. S. Nelson *et al.*, "Exploring the tolerability of spatiotemporally complex electrical stimulation paradigms," *Epilepsy Res.*, vol. 96, no. 3, pp. 267–275, 2011.
- [41] D. K. Freeman, D. K. Eddington, J. F. Rizzo, and S. I. Fried, "Selective activation of neuronal targets with sinusoidal electric stimulation," *J. Neurophysiol.*, vol. 104, no. 5, pp. 2778–2791, 2010.
- [42] L. Li *et al.*, "Intraorbital optic nerve stimulation with penetrating electrodes: *In vivo* electrophysiology study in rabbits," *Graefes Arch. Clin. Experim. Ophthalmol.*, vol. 247, no. 3, pp. 349–361, 2009.
- [43] O. Macherey, A. van Wieringen, R. P. Carlyon, J. M. Deeks, and J. Wouters, "Asymmetric pulses in cochlear implants: Effects of pulse shape, polarity, and rate," *J. Assoc. Res. Otolaryngol.*, vol. 7, no. 3, pp. 253–266, 2006.
- [44] G. Dumm, J. B. Fallon, C. E. Williams, and M. N. Shivdasani, "Virtual electrodes by current steering in retinal prostheses," *Invest. Ophthalmol. Vis. Sci.*, vol. 55, no. 12, pp. 8077–8085, 2014.
- [45] L. H. Jepson *et al.*, "Spatially patterned electrical stimulation to enhance resolution of retinal prostheses," *J. Neurosci.*, vol. 34, no. 14, pp. 4871–4881, 2014.



KYLE D. SLATER received the B.E. (Hons.) degree in electrical and electronic engineering and the B.S. degree in physics from The University of Melbourne, Australia, where he is currently pursuing the Ph.D. degree with the Department of Electrical and Electronic Engineering. He is developing custom integrated circuits for neuro stimulation and recording applications with The University of Melbourne. This project is in collaboration with the Bionics Institute,

Melbourne, Australia, and St. Vincent's Hospital, Melbourne.

He was an Electronic Engineer with the Bionics Institute for two years, where he was responsible for the design and development of clinical hardware and software systems, before commencing his Ph.D. He was recently a Visiting Scholar with the Department of Electrical Engineering and Computer Science, University of California at Berkeley. He is primarily interested in the application of electronic systems toward improving treatment and diagnosis of medical conditions.



NICHOLAS C. SINCLAIR received the B.E. (Hons.) degree in electrical/electronic engineering and the B.Sc. degree in medical biophysics and instrumentation from Swinburne University of Technology, Melbourne, Australia, in 2005.

He was involved in developing a depth of anesthesia monitor with Cortical Dynamics Ltd. He is currently a Research Engineer with the Bionics Institute, Melbourne, where he is part of a multidisciplinary team developing a bionic eye. His work has focused on the development of systems for performing visual psychophysics with bionic eye devices. He has been responsible for performing psychophysics experiments with retinal prosthesis implantees.



TIMOTHY S. NELSON, received the B.E. degree and the B.Sc. degree in biomedical engineering from Flinders University, Adelaide, Australia, in 2004. He was a Research Engineer and Project Manager with the Bionics Institute, Melbourne, from 2005 to 2011. He was responsible for the development of equipment for the treatment of epilepsy through electrical stimulation. He is currently based in Vanuatu, and is a Senior Program Manager for Save The Children.



PETER J. BLAMEY was born in Canberra, Australia, in 1951. He received the B.Sc. degree in theoretical physics from Australian National University, and the Ph.D. degree in nuclear physics from Monash University. He was a Trainee Actuary for two years. He found his niche as a member of Graeme Clark's team at The University of Melbourne, who were responsible for the research that led to the multielectrode cochlear implant or bionic ear, now

produced by Cochlear Ltd., Sydney. He holds over 25 patent families, many of which have reached the marketplace.

He and Dr. E. Saunders co-founded Dynamic Hearing Pty Ltd., for the development and commercialization of sound processing technologies for hearing aids and headsets in 2002. He is a Co-Owner of Blamey & Saunders Hearing Pty Ltd. He works part-time as a Principal Research Fellow with the Bionics Institute, where he leads the Bionic Eye Psychophysics Team for Bionic Vision Australia.

Prof. Blamey received the American Academy of Audiology International Award for significant and sustained contributions to the field of audiology and to hearing-impaired adults and children worldwide in 2007, and the Clunies Ross Medal from the Academy of Technological Science and Engineering for taking hearing aid technology from invention to commercial and clinical outcomes in 2012.

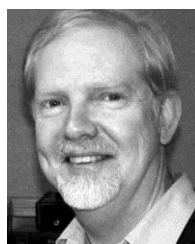

HUGH J. McDERMOTT (F'12) is currently the Deputy Director of the Bionics Institute, Melbourne, Australia, and holds an honorary appointment as a Professorial Fellow with The University of Melbourne. He has 30 years of experience in sound processing, electronic design, and perceptual research. Several of his inventions have been translated into successful commercial products, including the Speak/ACE sound-processing schemes for cochlear implants manufactured by Cochlear Ltd., and the SoundRecover frequency-compression scheme for hearing aids made by Phonak AG.

Prof. McDermott is a fellow of the Acoustical Society of America. In recognition of his leadership that has fostered scientific advances and significant developments in the diagnosis and treatment of communication disorders, he became the first winner of the Callier Prize in Communication Disorders by the University of Texas at Dallas, in 2009.